

◎ POWER RATING

Engine Speed rev/min	Type of Operation	Engine Power	
		kWm	Ps
1800	Continuous Power	113	153
	Prime Power	125	170
	Standby Power	138	187
1500	Continuous Power	97	131
	Prime Power	107	145
	Standby Power	118	160

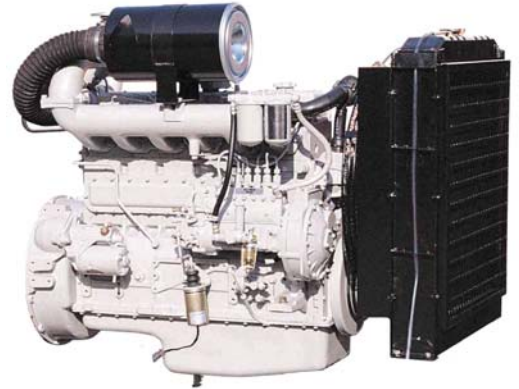

Note : -. The engine performance corresponds to ISO 3046, BS 5514 and DIN 6271.

-. Ratings are based on ISO 8528.

→ **Prime power** available at variable load. The permissible average power out put (during 24h period) shall not exceed 70% of the prime power rating.

→ **Standby power** available in the event of a main power network failure. No overload is permitted.

◎ MECHANICAL SYSTEM

○ Engine Model	D1146T
○ Engine Type	In-line 4 cycle, water cooled Turbo charged
○ Combustion type	Direct injection
○ Cylinder Type	Replaceable dry liner
○ Number of cylinders	6
○ Bore x stroke	111(4.37) x 139(5.47) mm(in.)
○ Displacement	8.071(492.49) lit.(in ³)
○ Compression ratio	16.8 : 1
○ Firing order	1-5-3-6-2-4
○ Injection timing	11° BTDC
○ Compression pressure	Above 28 kg/cm ² (398 psi) at 200rpm
○ Dry weight	Approx. 780 kg (1,720 lb)
○ Dimension (LxWxH)	1,277 x 824 x 1,074 mm (50.3 x 32.4 x 42.3 in.)
○ Rotation	Counter clockwise viewed from Flywheel
○ Fly wheel housing	SAE NO.2
○ Fly wheel	Clutch NO.11 1/2

◎ MECHANISM

○ Type	Over head valve
○ Number of valve	Intake 1, exhaust 1 per cylinder
○ Valve lashes at cold	Intake 0.30mm (0.0118 in.) Exhaust 0.30mm (0.0118 in.)

◎ VALVE TIMING

	Opening	Close
○ Intake valve	16 deg. BTDC	36 deg. ABDC
○ Exhaust valve	46 deg. BBDC	14 deg. ATDC

◎ FUEL CONSUMPTION

○ Prime Power (lit/hr)	1,500 rpm	1,800 rpm
25%	8.2	11.4
50%	13.6	18.1
75%	19.5	24.9
100%	25.9	32.5
○ Standby Power (lit/h)	1,500 rpm	1,800 rpm
25%	8.6	11.9
50%	14.3	19.6
75%	20.4	27.3
100%	27.0	35.1

◎ FUEL SYSTEM

○ Injection pump	Zexel in-line "AD" type
○ Governor	RSV type (all speed control)
○ Feed pump	Mechanical type
○ Injection nozzle	Multi hole type
○ Opening pressure	214 kg/cm ² (3,044 psi)
○ Fuel filter	Full flow, cartridge type
○ Used fuel	Diesel fuel oil

◎ LUBRICATION SYSTEM

○ Lub. Method	Fully forced pressure feed type
○ Oil pump	Gear type driven by crankshaft
○ Oil filter	Full flow, cartridge type
○ Oil pan capacity	High level 15.5 liters (4.09 gal.) Low level 12 liters (3.17 gal.)
○ Angularity limit	Front down 25 deg. Front up 25 deg. Side to side 25 deg.
○ Lub. Oil	Refer to Operation Manual

◎ COOLING SYSTEM

- Cooling method Fresh water forced circulation
- Water capacity 14 liters (3.70 gal.)
- (engine only)
- Pressure system Max. 0.9 kg/cm² (12.8 psi)
- Water pump Centrifugal type driven by belt
- Water pump Capacity 150 liters (39.6 gal.)/min
- at 1,800 rpm (engine)
- Thermostat Wax – pellet type
- Opening temp. 71°C
- Full open temp. 85°C
- Cooling fan Blower type, steel
- 590 mm diameter, 6 blade

◎ ELECTRICAL SYSTEM

- Charging generator 24V x 45A [or 12V x 26A] Aalternator
- Voltage regulator Built-in type IC regulator
- Starting motor 24V x 4.5kW [or 12V x 2.5kW]
- Battery Voltage 24V [or 12V]
- Battery Capacity 100 AH [or 150 AH] (recommended)
- Starting aid (Option) Block heater

◎ ENGINEERING DATA

- Water flow 130 liters/min @1,500 rpm
- 150 liters/min @1,800 rpm
- Heat rejection to coolant 17.4 kcal/sec @1,800 rpm
- Air flow 6.7 m³/min @1,500 rpm
- 10.6 m³/min @1,800 rpm
- Exhaust gas flow 25.7 m³/min @1,800 rpm
- Exhaust gas temp. 470 °C @1,800 rpm
- Max. permissible restrictions
- .Intake system 220 mmH₂O initial
- 635 mmH₂O final
- .Exhaust system 600 mmH₂O max.

◆ CONVERSION TABLE

- | | |
|------------------------------------|------------------------------------|
| in. = mm x 0.0394 | lb/ft = N.m x 0.737 |
| PS = kW x 1.3596 | U.S. gal = lit. x 0.264 |
| psi = kg/cm ² x 14.2233 | kW = 0.2388 kcal/s |
| in ³ = lit. x 61.02 | lb/PS.h = g/kW.h x 0.00162 |
| hp = PS x 0.98635 | cfm = m ³ /min x 35.336 |
| lb = kg x 2.20462 | |

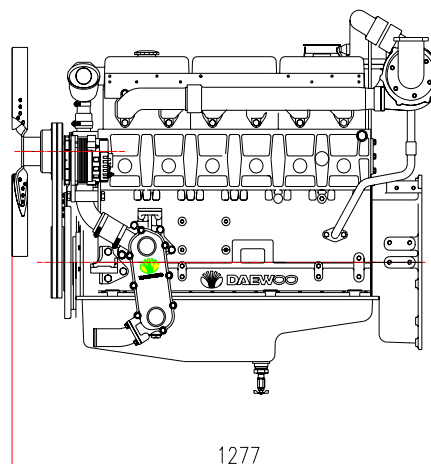
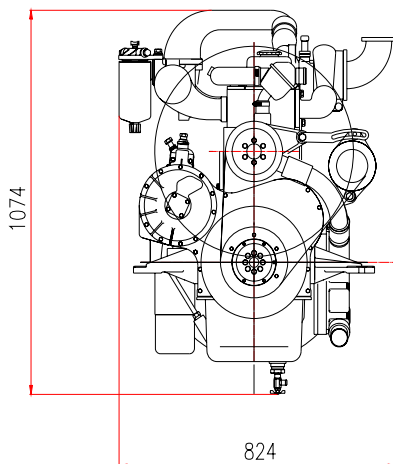

Head office

Room 1007, Building A, No. 399, Hengnan Road , Minhang District, Shanghai, China

TEL : 86-21-3328-2711, FAX : 86-21-3412-7993

Shanghai Diesel Engine Family Co.,Ltd

Email : sales@engine-family.com, info@engine-family.com

Web site : www.client-diesel.com, www.engine-family.com

※ Specifications are subject to change without prior notice