

## ◎ POWER RATING

| Intermittent rating<br>kW(PS) / rpm | Max. torque<br>N.m(kg.m) / rpm | Fuel consumption<br>g/kW.h(g/PS.h) / rpm |
|-------------------------------------|--------------------------------|--|
| 397 (540) / 2100                    | 2117 (216) / 1500              | 222 (163) / 2100                         |

- Note : 1. The engine performance corresponds to ISO 3046, DIN 6270B.  
 2. Continuous duty at charge and constant speed consider on engine choice, a power derating of about 11%.  
 3. Max. rpm of Continuous duty is 1,800rpm.



## ◎ MECHANICAL SYSTEM

- Engine Model PU158TI
- Engine Type V-type 4 cycle, water cooled  
Turbo charged & intercooled
- Combustion type Direct injection
- Cylinder Type Replaceable wet liner
- Number of cylinders 8
- Bore x stroke 128(5.04) x 142(5.59) mm(in.)
- Displacement 14.618(892.0) lit.(in<sup>3</sup>)
- Compression ratio 15 : 1
- Firing order 1-5-7-2-6-3-4-8
- Injection timing 18° BTDC
- Dry weight Approx. 950 kg (2,094 lb)
- Dimension 1,484 x 1,389 x 1,161.5 mm  
(58.4 x 54.7 x 45.7 in.)
- Rotation Counter clockwise viewed from Flywheel

## ◎ MECHANISM

- Type Over head valve
- Number of valve Intake 1, exhaust 1 per cylinder
- Valve lashes at cold Intake 0.25mm (0.0098 in.)  
Exhaust 0.35mm (0.0138 in.)

## ◎ VALVE TIMING

- |                 | Opening      | Close        |
|-----------------|--------------|--------------|
| ○ Intake valve  | 24 deg. BTDC | 36 deg. ABDC |
| ○ Exhaust valve | 63 deg. BBDC | 27 deg. ATDC |

## ◎ OPTION & ACCESSORY PARTS

- Engine parts Fly wheel & housing  
Intake & exhaust manifold
- Accessory parts Raditor, silencer & air cleaner
- Electrical parts Gauge panel & stop solenoid

## ◎ FUEL SYSTEM

- Injection pump Bosch in-line "P" type
- Governor Mechanical type
- Feed pump Mechanical type
- Injection nozzle Multi hole type
- Fuel filter Full flow, cartridge type
- Used fuel Diesel fuel oil

## ◎ LUBRICATION SYSTEM

- Lub. Method Fully forced pressure feed type
- Oil pump Gear type driven by crankshaft
- Oil filter Full flow, cartridge type
- Oil pan capacity High level 21 liters ( 5.55 gal.)  
Low level 17 liters ( 4.50 gal.)
- Angularity limit Front down 35 deg.  
Front up 35 deg.  
Side to side 35 deg.
- Lub. Oil Refer to Operation Manual

## ◎ PERFORMANCE CURVE

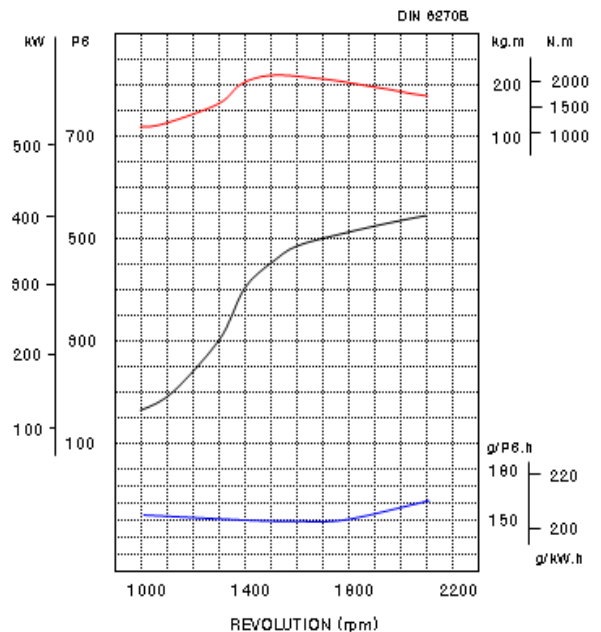

## ◎ COOLING SYSTEM

- Cooling method Fresh water forced circulation
- Water capacity 20 liters ( 5.28 gal.)  
(engine only)
- Pressure system Max. 0.5 kg/cm<sup>2</sup> ( 7.1 psi)
- Water pump Centrifugal type driven by belt
- Water pump Capacity 454 liters ( 120 gal.)/min  
at 2,100 rpm (engine)
- Thermostat Wax – pellet type  
Opening temp. 79°C  
Full open temp. 94°C
- Cooling fan Blower type, plastic  
915 mm diameter, 7 blade

## ◎ ELECTRICAL SYSTEM

- Charging generator 24V x 45A alternator
- Voltage regulator Built-in type IC regulator
- Starting motor 24V x 7.0kW
- Battery Voltage 24V
- Battery Capacity 200 AH (recommended)
- Starting aid (Option) Block heater

## ◎ ENGINEERING DATA

- Water flow 454 liters/min @2,100 rpm
- Heat rejection to coolant 45.2 kcal/sec @2,100 rpm
- Heat rejection to CAC 18.8 kcal/sec @2,100 rpm
- Air flow 34.5 m<sup>3</sup>/min @2,100 rpm
- Exhaust gas flow 87.4 m<sup>3</sup>/min @2,100 rpm
- Exhaust gas temp. 600 °C @2,100 rpm
- Max. permissible restrictions
  - Intake system 220 mmH<sub>2</sub>O initial  
635 mmH<sub>2</sub>O final
  - Exhaust system 1000 mmH<sub>2</sub>O max.

## ◆ CONVERSION TABLE

|                                    |                                    |
|------------------------------------|------------------------------------|
| in. = mm x 0.0394                  | lb/ft = N.m x 0.737                |
| PS = kW x 1.3596                   | U.S. gal = lit. x 0.264            |
| psi = kg/cm <sup>2</sup> x 14.2233 | kW = 0.2388 kcal/s                 |
| in <sup>3</sup> = lit. x 61.02     | lb/PS.h = g/kW.h x 0.00162         |
| hp = PS x 0.98635                  | cfm = m <sup>3</sup> /min x 35.336 |
| lb = kg x 2.20462                  |                                    |

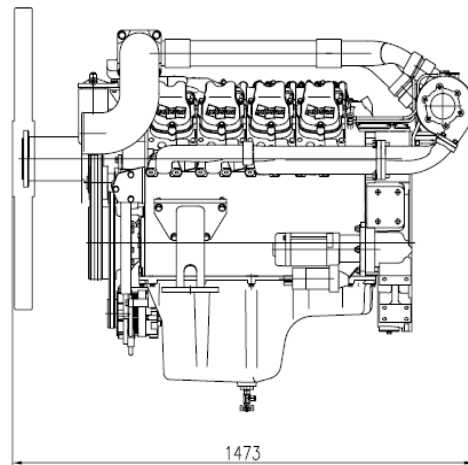
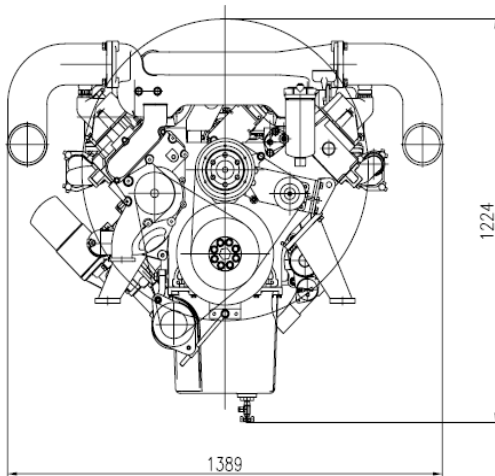

### Head office

Tqqo "3229."Dwrf kpi "C."Pq05; ; .J gpi pcp" Tqcf ". "O kpi cpi "F kntlev""  
Uj cpi j ck' Ej kpc

VGN" 8/43/554: /4933. HCZ' 8/43/5634/9; ; 5

Uj cpi j ckF kgur! Cpi kpg' Hco kq' 'Eq0Nf

Email : sales@engine-family.com, info@engine-family.com

Web site : www.client-diesel.com, www.engine-family.com