

PU180TI P-DRIVE

◎ POWER RATING

Intermittent rating kW(PS) / rpm	Max. torque N.m(kg.m) / rpm	Fuel consumption g/kW.h(g/PS.h) / rpm
478 (650) / 2100	2303 (235) / 1500	226 (166) / 2100

Note : 1. The engine performance corresponds to ISO 3046, DIN 6270B.
 2. Continuous duty at charge and constant speed consider on engine choice, a power derating of about 9%.
 3. Max. rpm of Continuous duty is 1,800rpm.

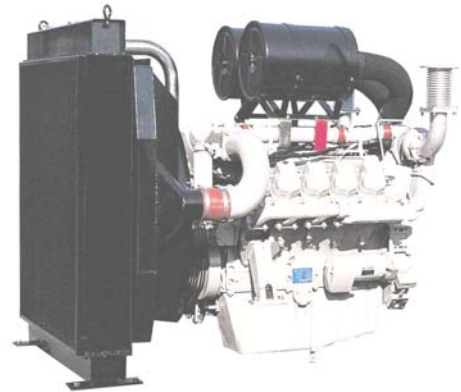

◎ MECHANICAL SYSTEM

- Engine Model PU180TI
- Engine Type V-type 4 cycle, water cooled
Turbo charged & intercooled
- Combustion type Direct injection
- Cylinder Type Replaceable wet liner
- Number of cylinders 10
- Bore x stroke 128(5.04) x 142(5.59) mm(in.)
- Displacement 18.273(1,115.02) lit.(in³)
- Compression ratio 15 : 1
- Firing order 1-6-5-10-2-7-8-3-4--9
- Injection timing 18° BTDC
- Dry weight Approx. 1,175 kg (2,590 lb)
- Dimension 1,557 x 1,389 x 1,248 mm
(LxWxH) (61.3 x 54.7 x 49.1 in.)
- Rotation Counter clockwise viewed from Flywheel

◎ MECHANISM

- Type Over head valve
- Number of valve Intake 1, exhaust 1 per cylinder
- Valve lashes at cold Intake 0.25mm (0.0098 in.)
Exhaust 0.35mm (0.0138 in.)

◎ VALVE TIMING

	Opening	Close
○ Intake valve	24 deg. BTDC	36 deg. ABDC
○ Exhaust valve	63 deg. BBDC	27 deg. ATDC

◎ OPTION & ACCESSORY PARTS

- Engine parts Fly wheel & housing
Intake & exhaust manifold
- Accessory parts Raditor, silencer & air cleaner
- Electrical parts Gauge panel & stop solenoid

◎ FUEL SYSTEM

- Injection pump Bosch in-line "P" type
- Governor Mechanical type
- Feed pump Mechanical type
- Injection nozzle Multi hole type
- Fuel filter Full flow, cartridge type
- Used fuel Diesel fuel oil

◎ LUBRICATION SYSTEM

- Lub. Method Fully forced pressure feed type
- Oil pump Gear type driven by crankshaft
- Oil filter Full flow, cartridge type
- Oil pan capacity High level 35 liters (9.2 gal.)
Low level 28 liters (7.4 gal.)
- Angularity limit Front down 24 deg.
Front up 20 deg.
Side to side 15 deg.
- Lub. Oil Refer to Operation Manual

◎ PERFORMANCE CURVE

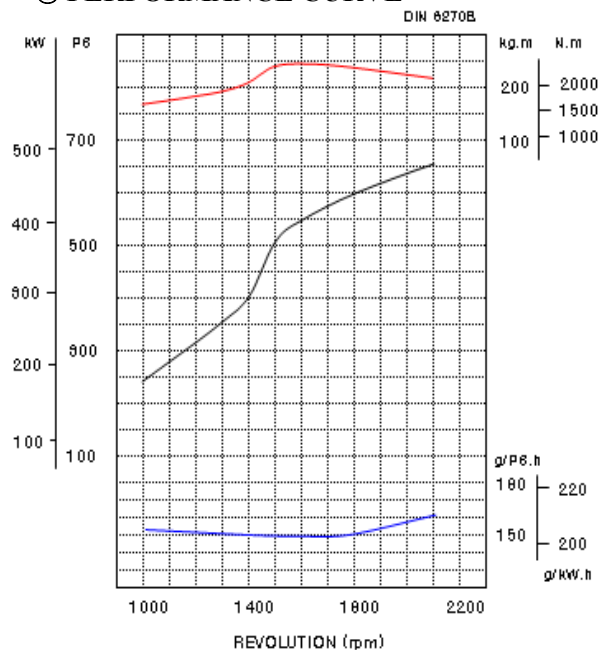

◎ COOLING SYSTEM

- Cooling method Fresh water forced circulation
- Water capacity 21 liters (5.54 gal.)
(engine only)
- Pressure system Max. 0.5 kg/cm² (7.1 psi)
- Water pump Centrifugal type driven by belt
- Water pump Capacity 454 liters (120 gal.)/min
at 2,100 rpm (engine)
- Thermostat Wax – pellet type
Opening temp. 79°C
Full open temp. 94°C
- Cooling fan Blower type, plastic
915 mm diameter, 7 blade

◎ ELECTRICAL SYSTEM

- Charging generator 24V x 45A alternator
- Voltage regulator Built-in type IC regulator
- Starting motor 24V x 7.0kW
- Battery Voltage 24V
- Battery Capacity 200 AH (recommended)
- Starting aid (Option) Block heater

◎ ENGINEERING DATA

- Water flow 454 liters/min @2,100 rpm
- Heat rejection to coolant 54.4 kcal/sec @2,100 rpm
- Heat rejection to CAC 22.7 kcal/sec @2,100 rpm
- Air flow 38.0 m³/min @2,100 rpm
- Exhaust gas flow 107 m³/min @2,100 rpm
- Exhaust gas temp. 600 °C @2,100 rpm
- Max. permissible restrictions
 - Intake system 220 mmH₂O initial
635 mmH₂O final
 - Exhaust system 1000 mmH₂O max.

◆ CONVERSION TABLE

- | | |
|------------------------------------|------------------------------------|
| in. = mm x 0.0394 | lb/ft = N.m x 0.737 |
| PS = kW x 1.3596 | U.S. gal = lit. x 0.264 |
| psi = kg/cm ² x 14.2233 | kW = 0.2388 kcal/s |
| in ³ = lit. x 61.02 | lb/PS.h = g/kW.h x 0.00162 |
| hp = PS x 0.98635 | cfm = m ³ /min x 35.336 |
| lb = kg x 2.20462 | |

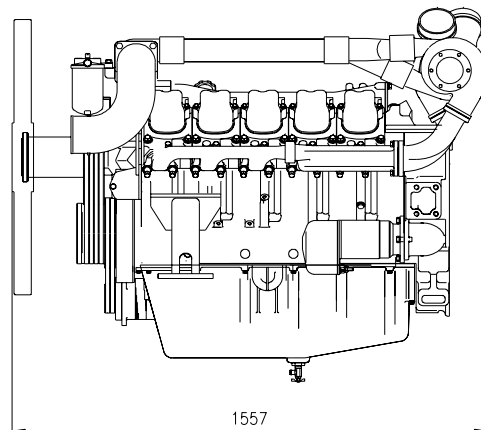
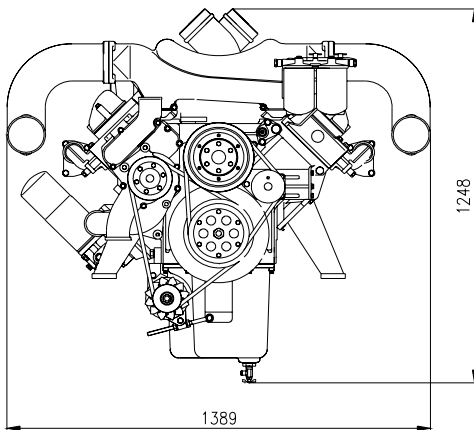

Head office

Room 1007, Building A, No. 399, Hengnan Road , Minhang District,
Shanghai, China

TEL : 86-21-3328-2711, FAX : 86-21-3412-7993

Shanghai Diesel Engine Family Co.,Ltd

Email : sales@engine-family.com, info@engine-family.com

Web site : www.client-diesel.com, www.engine-family.com

※ Specifications are subject to change without prior notice